

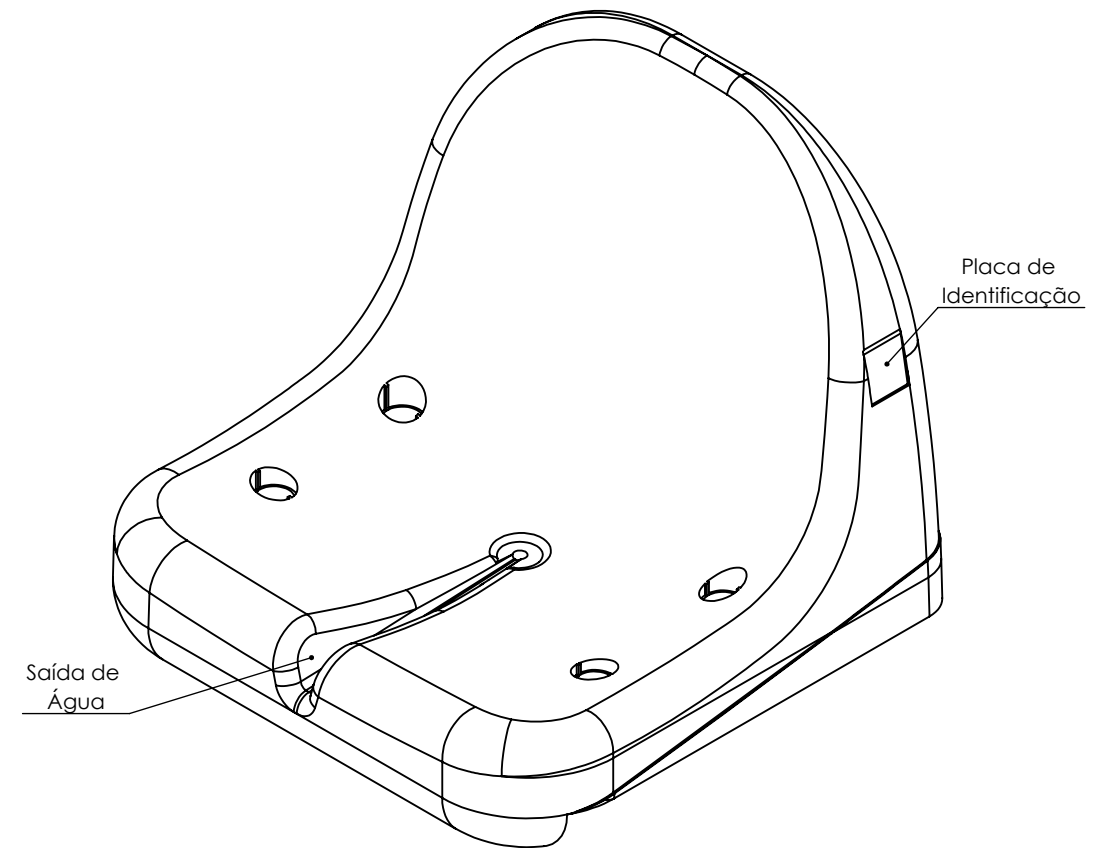

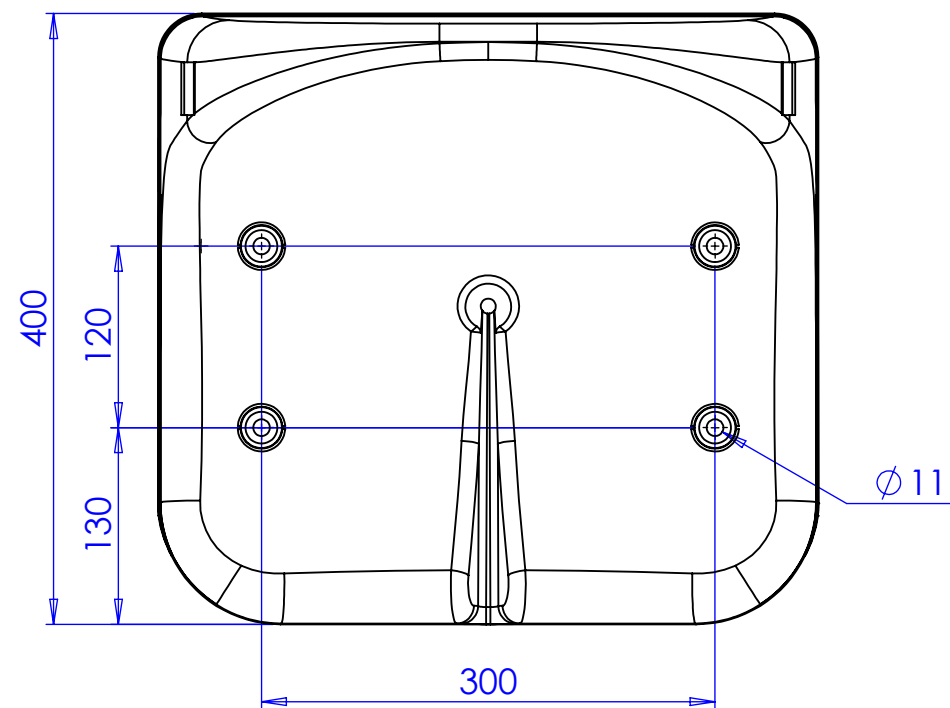

SEÇÃO B-B

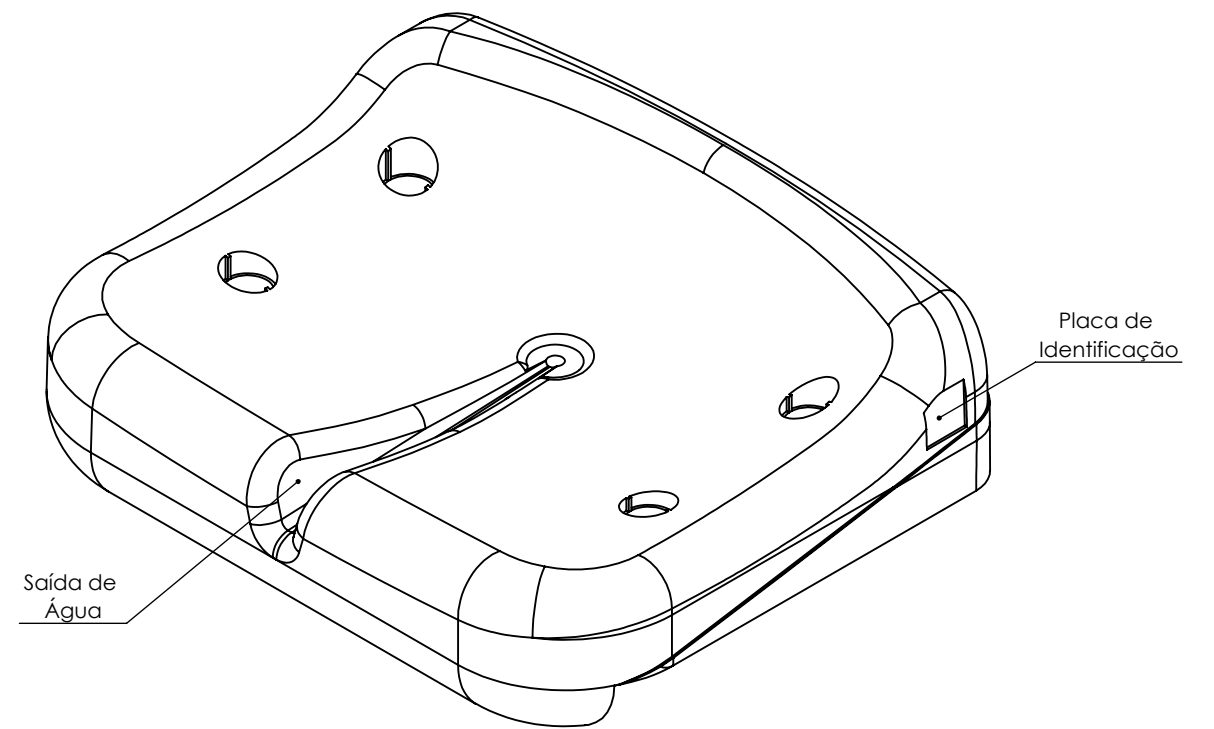
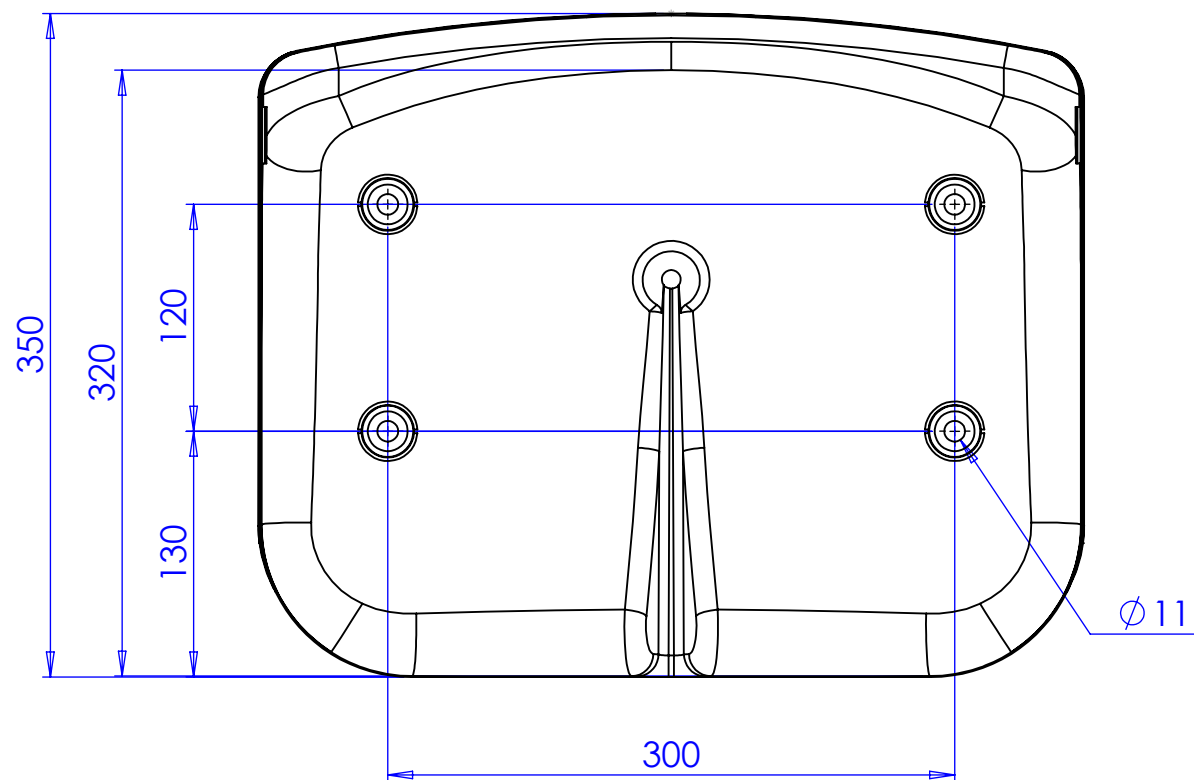
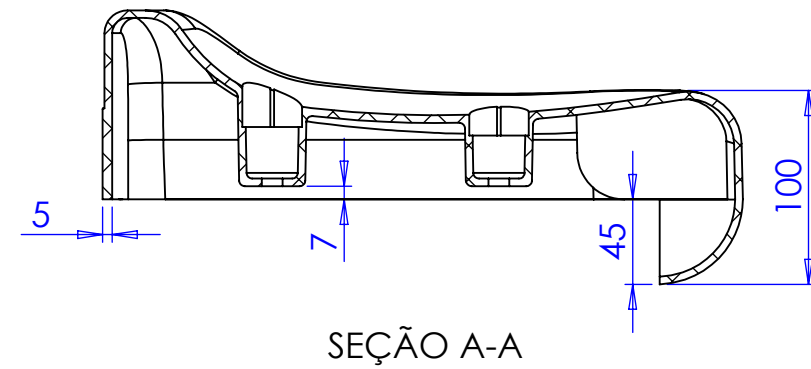
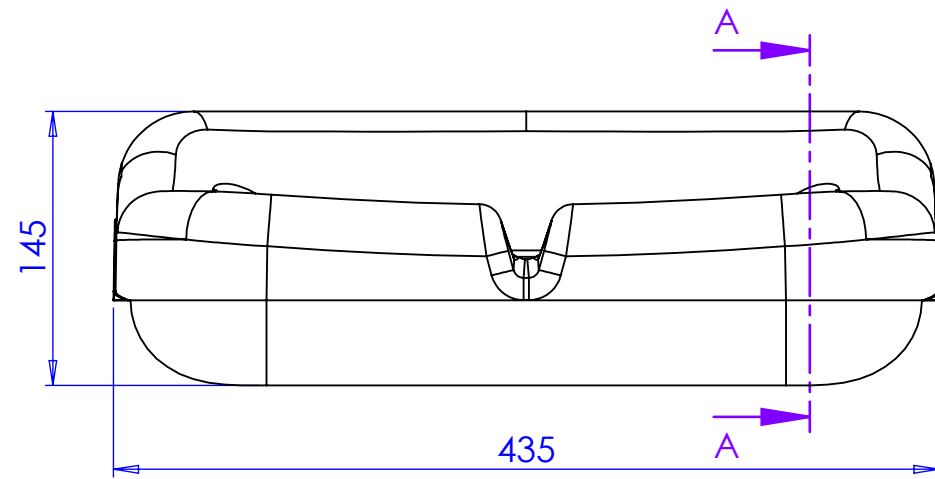

	LINHA:	VERSÃO: c/ Enc.	CONCHA ESTADIO COM ENCOSTO		
	DIMENSÃO: CONF. DES.	OBS: -		QTD: -	
	PROJETISTA:	DESENHISTA: Renato	CAD:	REV.: 02/10/2018	
	CÓD. MP:	MATERIAL: PP - Aditivado - Anti Chama	PESO: 1.953Kg	ÁREA: 1.109m ²	VOLUME: 0.002m ³
	CÓD. NUM: -	FPC7190U--			ESCALA: 1:5
CÓD. ALF: FPC7190U--					FOL: 1/1

X= ± 0.2 X= ± 0.1 XX= ± 0.05
TOL. NÃO INDICADAS NO DESENHO



	LINHA : ESTADIO	VERSÃO : s/ Enc.	CONCHA ESTADIO SEM ENCOSTO		
	DIMENSÃO : CONF.DES.	OBS : -			QTD : -
	PROJETISTA :	DESENHISTA : Renato	CAD :	REV. :	02/10/2018
	CÓD . MP :	MATERIAL : PP - Aditivado - Anti Chama	PESO : 1.155Kg	ÁREA : 0.657m ²	VOLUME : 0.001m ³
	CÓD . NUM : -	FPC7191U--			ESCALA : 1:4
TOL. NÃO INDICADAS NO DESENHO		CÓD . ALF : FPC7191U--			FOL . 1 / 1

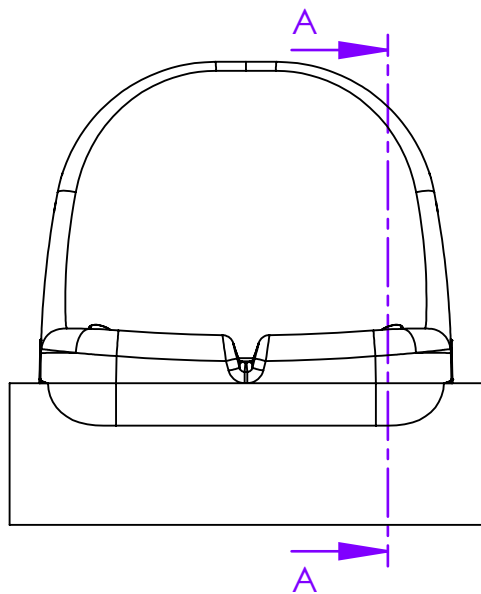

SEÇÃO A-A

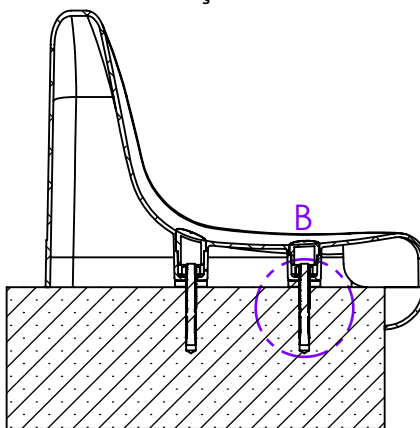

DETALHE B
ESCALA 1 : 2

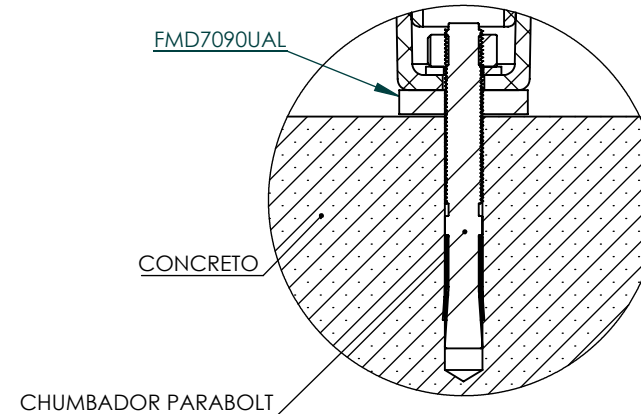

DETALHE C
ESCALA 1 : 2

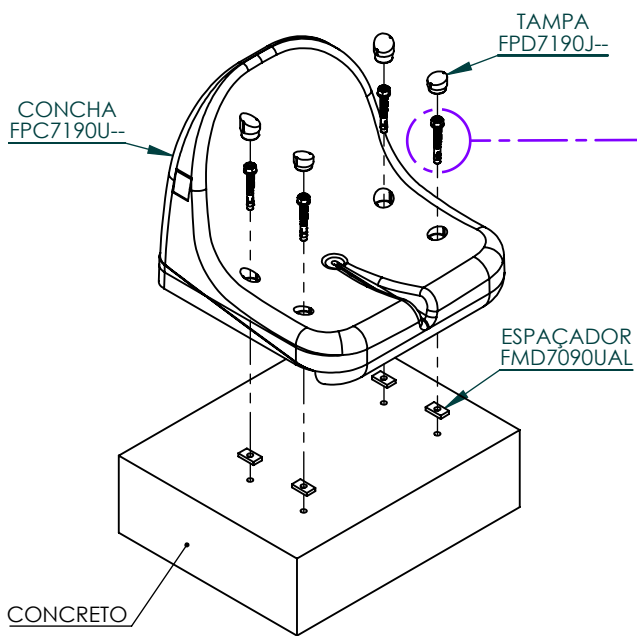
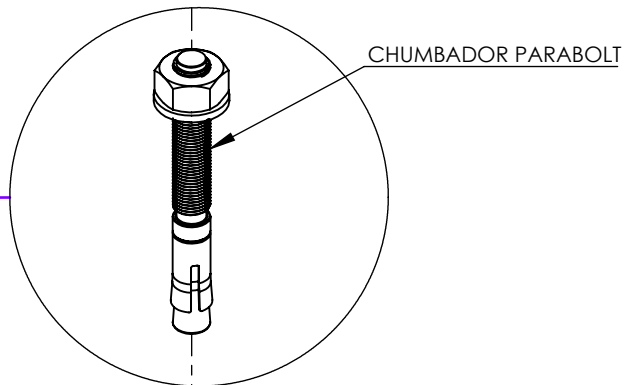

Aplicação do Chumbador:

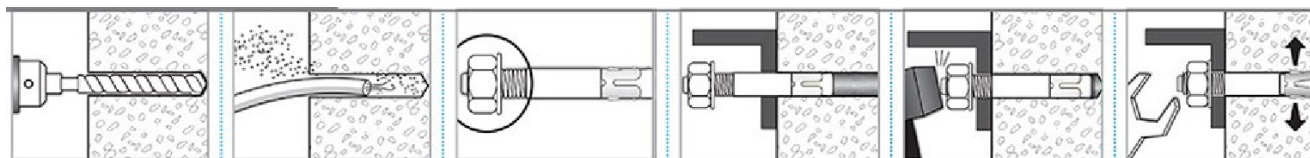

Faça o furo com diâmetro e profundidade indicados pelo fabricante.

Limpe o furo.

Coloque a porca e a arruela na extremidade do chumbador.

Posicione a peça a fixa e introduza o chumbador

Com auxílio de marreta introduza o chumbador no furo

Aperte a porca provocando a expansão concluindo a fixação

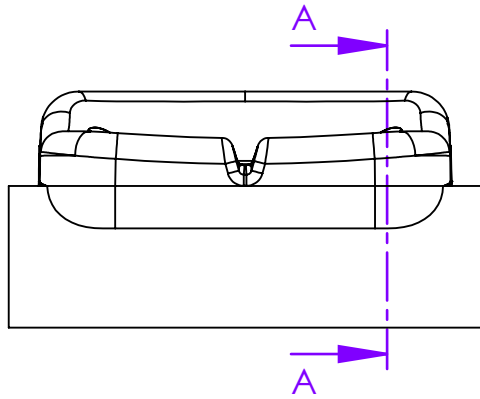

SEÇÃO A-A

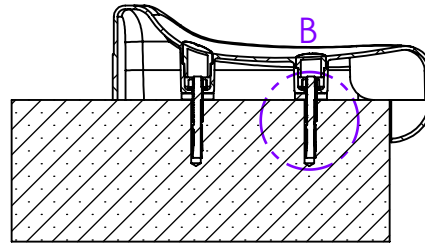

DETALHE B
ESCALA 1 : 2

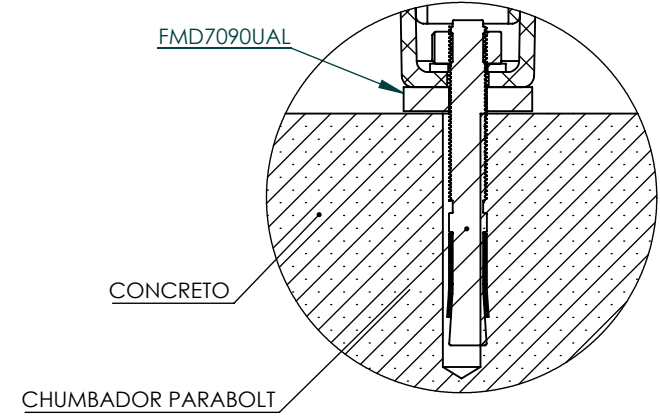

DETALHE C
ESCALA 1 : 2

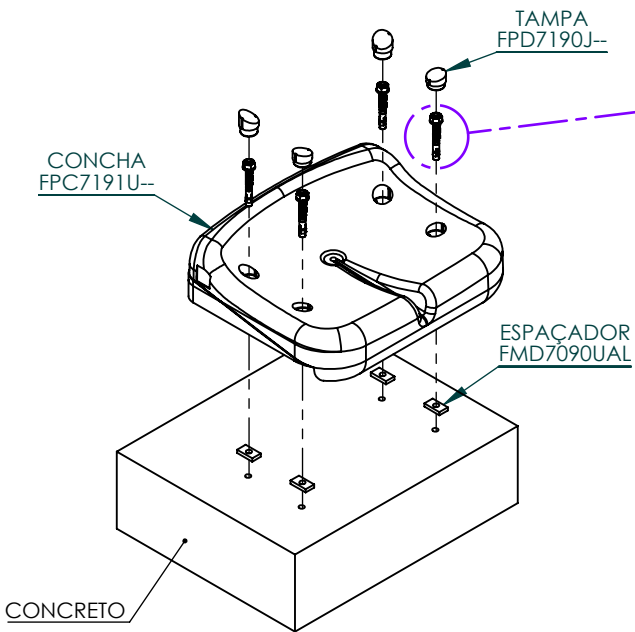
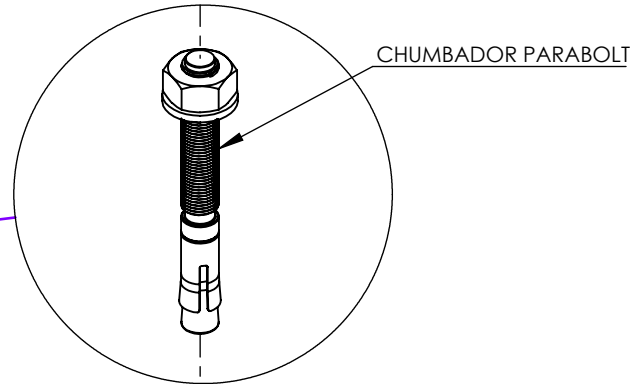

Aplicação do Chumbador:

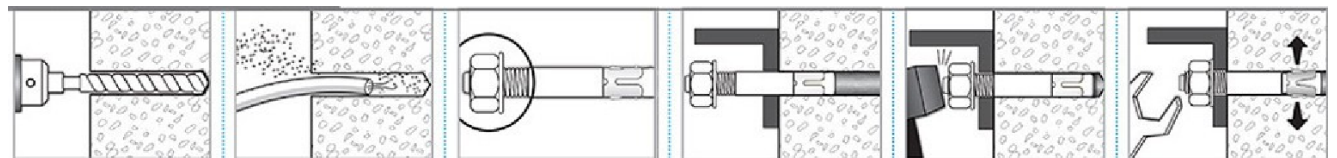

Faça o furo com diâmetro e profundidade indicados pelo fabricante.

Limpe o furo.

Coloque a porca e a arruela na extremidade do chumbador.

Posicione a peça a fixa e introduza o chumbador

Com auxílio de marreta introduza o chumbador no furo

Aperte a porca provocando a expansão concluindo a fixação